

KOMATSU

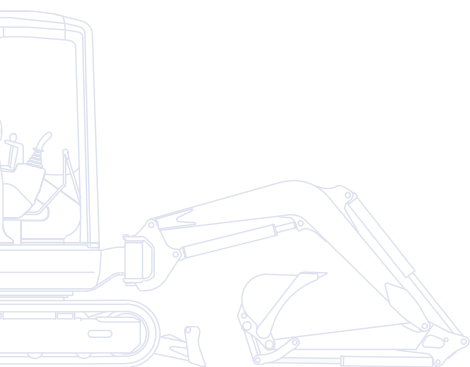

Mini-Excavator **PC09-1**



ENGINE POWER
6,8 kW / 9,1 HP @ 2.200 rpm

OPERATING WEIGHT
880 - 1.080 kg

BUCKET CAPACITY
0,016 - 0,025 m³

Walk-Around

The PC09-1 micro-excavator is the result of the competence and technology that Komatsu has acquired over 80 years. It was designed and developed with constant attention to the needs of customers from all over the world. The end result is a user-friendly machine that offers top-class performance.

Outstanding performance

- Agile and precise
- Extremely compact
- Superior hydraulic system
- Excellent efficiency and reliability

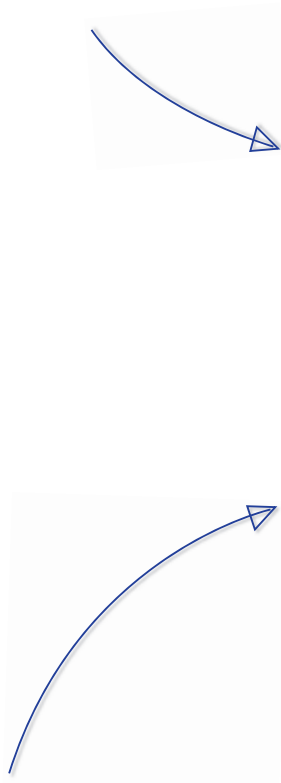

Total versatility

- Two travel speeds
- Variable width undercarriage
- Arm with integrated demolition breaker (option)

PC09-1

ENGINE POWER
6,8 kW / 9,1 HP @ 2.200 rpm

OPERATING WEIGHT
880 - 1.080 kg

BUCKET CAPACITY
0,016 - 0,025 m³

Extremely robust

- Cast body
- Tubular boom
- Metal bonnet



Safe and environment friendly

- Safety lock lever
- Recycle-oriented design
- Low noise levels

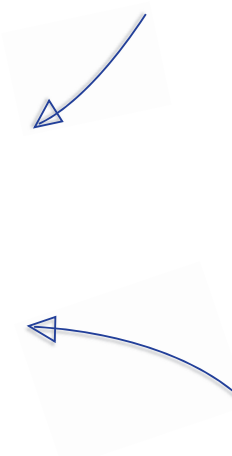

Easy maintenance

- Easy access to all inspection points
- Full opening bonnet
- Long interval greasing

Outstanding performance

Extremely compact

The new PC09-1 micro-excavator has exactly the right power and digging force for operating in tight spaces: ideal inside buildings, for small demolition work, to set plants or install an irrigation system in a garden, and, in general, on any job site where a bigger machine can't work or even be transported to.

Superior hydraulic system

Thanks to its cutting edge hydraulic system, all movements - even when combined - are smooth and shock-free for maximum precision, in any application. The PC09-1 is a perfect mix of the care that a manual worker can bring to a job and of an excavator's high performance. It makes any job much easier and quicker to finish.



Variable width undercarriage

For applications requiring maximum versatility in terms of size and stability, the PC09-1 is equipped with a hydraulic undercarriage extension operated from the driver's seat via a dedicated control. This feature allows the operator to quickly switch from maximum stability for digging, to a reduced width of less than one meter to easily drive through narrow passages or doors.

Arm with integrated demolition breaker (optional)

With this option, the PC09-1 can switch from a digging job to a demolition application in just a few seconds: You can use the breaker without removing the bucket, by simply installing the provided point. The PC09-1 then becomes a 2-in-1 machine and you don't need to carry other special tools for top functionality and efficiency.



Extremely robust



Built to last

Several technical solutions give the PC09-1 increased sturdiness and operability. The cast body offers extreme rigidity and robustness, and the metal bonnet guarantees a longer life and lower repairing costs in the event of a collision. A special tubular boom with no welding houses all hydraulic hoses and protects them from possible damage while allowing complete visibility of the digging area.



ENGINE

Model	Komatsu 2D68E-3A
Displacement.....	522 cm ³
Engine power	
at rated engine speed	2.200 rpm
ISO 14396.....	6,8 kW / 9,1 HP
ISO 9249 (net engine power)	6,3 kW / 8,4 HP
Cooling system.....	water

OPERATING WEIGHT

Operating weight with standard bucket, fully serviced, +75 kg operator (ISO 6016).	
Operating weight with rubber shoes	880 kg
Arm with hydraulic breaker.....	+100 kg (optional)
TOPS canopy	+100 kg (optional)

HYDRAULIC SYSTEM

Main pumps.....	2× gear pump
Max. pump flow.....	11 + 11 ltr/min
Max. operating pressure.....	16 MPa (160 bar)
Max. breakout force	1.130 daN (1.075 kg)

HYDRAULIC BREAKER

Impact energy.....	108 J (11 kgm)
Impact rate	800 bpm

DIMENSIONS

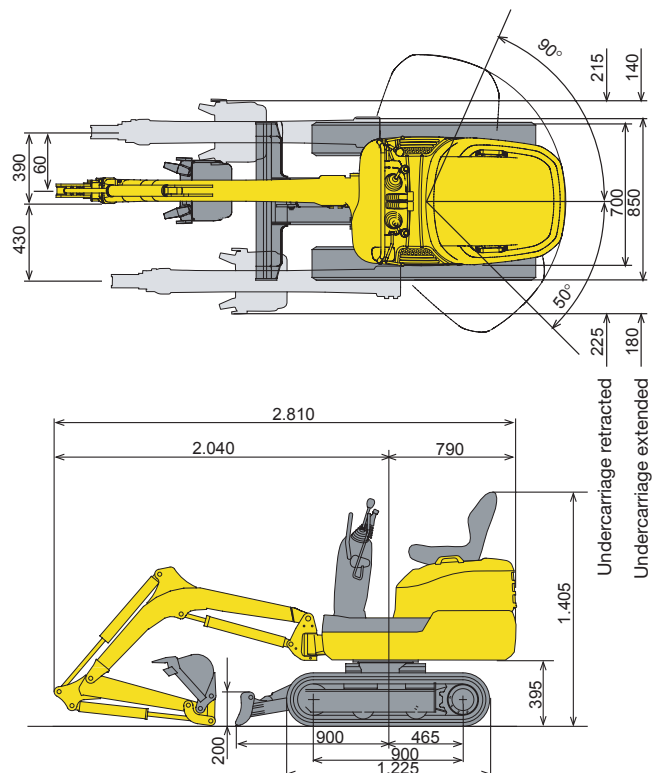

UNDERCARRIAGE

Blade - width × height	700 × 200 mm
Shoe width	180 mm
Ground pressure (standard).....	0,25 kg/cm ²
Variable undercarriage	

TRANSMISSION

Type	double speed hydrostatic transmission, controlled and steered by means of two levers
Max. drawbar pull.....	1.160 daN (1.090 kg)
Travel speed	1,5 - 3,0 km/h

SERVICE CAPACITIES

Fuel tank.....	10,8 ltr
Engine oil.....	1,9 ltr
Hydraulic oil tank.....	16,4 ltr

ENVIRONMENT

Vibration levels (EN 12096:1997)*	
Hand/arm	≤ 2,5 m/s ² (uncertainty K = 0,1 m/s ²)
Body	≤ 0,5 m/s ² (uncertainty K = 0,0 m/s ²)
* for the purpose of risk assessment under directive 2002/44/EC, please refer to ISO/TR 25398:2006.	

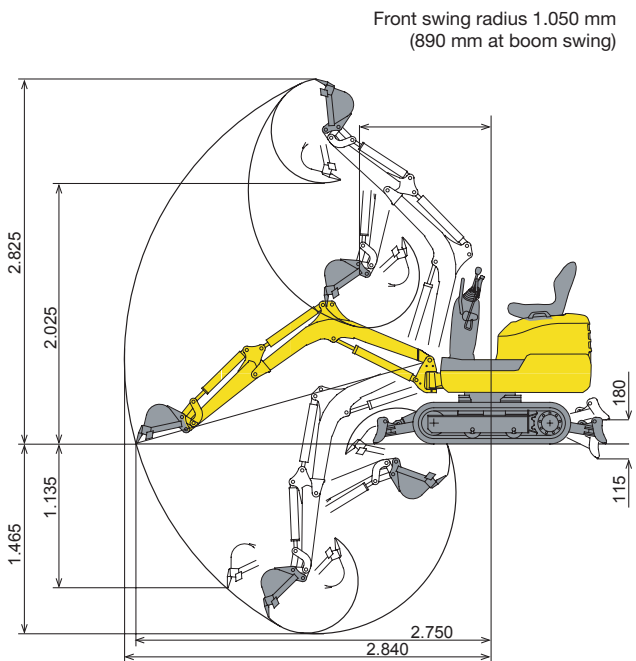

Mini-Excavator

PC09-1

Standard Equipment

- Two travel speeds
- Variable undercarriage
- Front blade
- ORFS connections
- One piece cast iron frame
- Metal bonnet
- Safety lock lever

Optional Equipment

- Arm with hydraulic breaker
- TOPS canopy
- Komatsu buckets

Fuel:

Diesel fuel, conforming to EN590 Class 2/Grade D. Paraffinic fuel capability (HVO, GTL, BTL), conforming to EN 15940:2016

Your Komatsu partner:



**Komatsu Europe
International NV**
Mechelsesteenweg 586
B-1800 VILVOORDE (BELGIUM)
Tel. +32-2-255 24 11
Fax +32-2-252 19 81
www.komatsu.eu

WESS006402 06/2022

Materials and specifications are subject to change without notice.
KOMATSU is a trademark of Komatsu Ltd. Japan.